

The Surelok III

With versatile design and unsurpassed features, the Surelok III outperforms the competition like no other.

Superior features include

- 25" throat
- Fasten material from 32 gauge up to 14 gauge*
- Standard reverse tooling for better access and tooling orientation options
- APU – advanced power unit is faster, smoother, quieter and uses less air
- Stainless steel ready with simple punch and die change
- Adjustable 2-1/2" (63mm) stroke
- Air powered, requires no electrical hook up

When you combine all the features, benefits and quality, the Surelok III sets the standard by which other clinching machines are measured.



INNOVATIONS IN ENGINEERING

SPECIFICATIONS – SURELOK III

Press Design: 3" Thick (76mm) steel "C" frame.
Rigid steel frame = longer tool life

Features: APU pneumatic power unit.
Regulator, Shut-off valve
Foot pedal operated

Stroke: 2 1/2" (63mm) max. (adjustable)
"Intelligent" safety stroke for greater operator safety.

Throat: 25" (635mm)
Work Height: 45" (1143mm)

Upper Tooling: Round or Rectangular ready
Close tooling access allows for more applications.
Simple adjustments to suit material thickness.

Lower Tooling: Die insert on a hardened die plate with a hardened protection collar.

Capacity: MAX: 2 ply .075" (1.9mm) mild steel.
MIN: 2 ply .010" (.25mm) mild steel.
MAX: 2 ply .050" (1.25mm) Stainless.
MIN: 2 ply .010" (.25mm) Stainless.
(Rectangular tooling for stainless)

Cycle speed: 60-80 cycles/minute (standard)
Up to 150 cycles/minute with options

Air Requirements: 80psi to 100psi (5.4 - 6.8 Bar)
100psi (6.8 Bar) (recommended)
Approx .2 cu ft (.0056 cu m) free air per cycle.
2 HP (1.5 kW) @ 60 clinches per min.

Weight: SL 25: 1300 lb (591kg)

Typical Joint Strengths in Mild Steel:

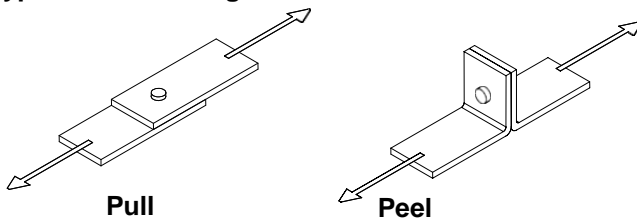

Material Thickness" (mm)	Pull lbs(N)	Peel lbs(N)	Die Type
.075 (1.9)	550 (2447)	225 (1001)	#50
.060 (1.5)	475 (2113)	175 (778)	#50
.050(1.25)	430 (1913)	150 (667)	#40/#50
.040 (1.0)	400 (1779)	120 (534)	#40
.034 (.86)	375 (1668)	100 (445)	#30/#40
.028 (.71)	325 (1446)	85 (378)	#30
.022 (.55)	285 (1268)	70 (311)	#30

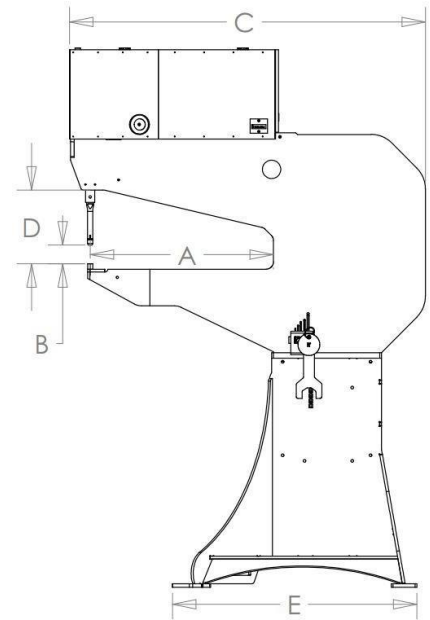

SL 25

A	25" [635mm]
B	2.5" [63mm]
C	48.5" [1232mm]
D	10" [254mm]
E	33" [838mm]
F	37.5" [953mm]
G	45" [1143mm]
H	74.5" [1892mm]

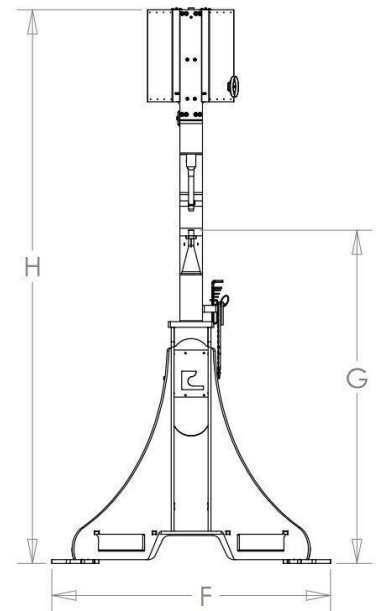

Pipe diameter Die reach into Pipe

3" (76mm) Ø	1-3/8" (34.9mm)
4" (102mm) Ø	3 1/4" (82.5mm)
5" (127mm) Ø	5" (127mm)
6" (152mm) Ø	12-1/4" (311mm)
7" (178mm) Ø	13-5/8" (346mm)
8" (203mm) Ø	15-7/8" (403mm)
9" (229mm) Ø	18-1/8" (460mm)
10" (254mm) Ø	20-1/2" (521mm)*
11" (279mm) Ø	22-3/4" (578mm)*
12" (305mm) Ø	24-1/2" (622mm)*